



Magic

MD-02

Dual Door Access Controller

“Series 5”



IMPORTANT DIFFERENCES FROM SERIES 4

1. All programming can only be done through devices attached to DTA1.
2. A MDL data logger revision 4.0 or higher attached to the DLOG terminal is able to program all features (i.e. times, relay type, etc.) and codes (including the management code) on the MD-02 series 5.
3. When using a MDL revision 4.0 or higher with a MD-02 Series 5 it is not necessary to have a management code programmed.

<u>TABLE OF CONTENTS</u>	<u>PAGE</u>
Introduction	1
Features	1
Specifications	2
Terminal Descriptions	3
Programmable Features Description	5
Automatic Relock Function.....	5
Door Open Too Long.....	5
Door Forced Open.....	5
One Minute Lockout	6
Use Two Codes	6
Installation	7
Basic Keypad Wiring	7
D.C. Lock.....	8
A.C. Lock.....	8
RTE Switch.....	8
Door Switch	8
Programming	9
Keypad Responses	10
Reset All Memories Codes.....	10
Basic Set Up Sequence	11
Automatic Relock. Memory 80	12
RTE Switch Type. Memory 81.....	12
ELC Relay Type. Memory 82	12
ELC Operating Time. Memory 83.....	13

Door Input Enable. Memory 84	13
Door Open Too Long Timer. Memory 85	13
Door Forced Open Detection. Memory 86	14
One Minute Lockout. Memory 87	14
Use Two Codes. Memory 88.....	14
Two Codes Timing. Memory 89	15
The Management Code. Memory 9.....	16
User Codes. Memories 000 to 399.....	17
To Program In A New User Code	18
To Change The Code Type.....	18
To Delete A User Code	19
Design Philosophy - Problems and Solutions.....	20
Warranty	20
Security & Protection	21
Other Models And Accessories	21
Programming Summary.....	22

INTRODUCTION

The Magic Digital Door Access Decoder utilizes microprocessor technology to operate most electric door locking devices on the market. The decoder together with an encoder (Magic keypad (MK-01 or MK-02) or a Magic Prox) offers access control to restricted areas.

FEATURES

- Split system for maximum security (Encoder & Decoder).
- Door Forced Open detection.
- Door Open Too Long (DOTL) function.
- RTE function.
- Automatic door relock function.
- Easy on site programming using Magic keypad.
- 400 client programmable users.
- Up to 10 encoders can be connected to one decoder.
- Two Heavy Duty 5 Amp. relay contacts for lock control.
- Can operate Fail Safe or Fail Secure electronic locking mechanisms.
- Two 1 Amp Normally Open DOTL Alarm relay outputs.
- 10 year non volatile EEPROM memory.
- Operating Temperature Range: 32°F to 158°F.
- 36 month (3 year) manufacturer's warranty.

SPECIFICATIONS

Voltage:

Min operating Voltage¹ 11 Volts D.C.

14 Volts A.C.

Max operating Voltage² 30 Volts D.C.

28 Volts A.C.

Current: D.C.³

40mA. quiescent.

200mA. MAX.

A.C.⁴

50mA. quiescent.

240mA. MAX.

ELC contacts:

30 Volt, 5 Amp A.C./D.C. SPST.

(Electric Latch Control) Programmable as N.O. or N.C.

DOTL contacts:

30 Volt, 1 Amp A.C./D.C. SPST.

(Door Open Too Long)

Operating Temperature:

32°F to 158°F (0°C to 70°C).

Size:

4 1/8" x 2 7/8" x 1 1/8"

(104mm x 72mm x 27mm).

Weight:

5.3 oz (150gms).

¹ Operating the unit at a Voltage lower than that specified may cause intermittent operation possibly resulting in damage to the unit.

² Exceeding the maximum specified input voltage may cause damage to the unit

³ Maximum D.C. current is drawn at 14 Volts input.

⁴ Maximum A.C. current is drawn at 16 Volts input.

TERMINAL DESCRIPTIONS

A general description for each terminal type is given below. An **x** has been used in place of a **1** or **2** where a terminal performs the same function for door 1 and door 2.

- GND** Negative input (or ground) from the power supply.
- AC-DC** A.C. 16 - 24 Volt or D.C. 12 - 24 Volt positive input from the power supply.
- DTAx** Data line to encoder (white wire on keypads).
- LEDx** Output to drive a LED to indicate door unlocked.
- ELCx** (Electric Latch Control) 5 Amp relay output. The ELC relay is used to control the door locking/release mechanism. The relay can be programmed as either Normally Open for **fail secure** applications (power applied to **open** door) or Normally Closed for **fail safe** applications (power applied to **lock** door).
- DOORx** This input requires a normally closed switch connected to ground, typically a magnetic contact attached to the door. The DOOR input is used by the MD-02 to monitor when the door is physically open (not unlocked). In order to use this input it must first be enabled (via memory 84, refer to page 13) and a normally closed (when the door is closed) door switch (or monitored lock contacts) must be connected between DOOR and GND. The DOOR input is used to detect when the door has been opened for use by the door forced open, Door Open Too Long and automatic relock functions.

DOTLx (Door Open Too Long) 1 Amp Normally Open relay output, operates when a DOTL or Door Forced Open alarm condition occurs.

RTE_x The RTE input can take either a normally open or normally closed switch between RTE and GND. When this input is activated the ELC relay will come on and remain on for the time that the RTE input is on. Once the RTE input is released the timing set for ELC will begin. The other selected features of the MD-02 (DOTL, Door Forced Open & Automatic Relock) will also become active at this time. Therefore the RTE input can be used to hold the door open indefinitely with the use of a toggle switch, or with the use of a momentary type switch it can be used to release the door for a set time in exactly the same way that a momentary user code does.

DLOG Data input/output for optional MDL data logger.

PROGRAMMABLE FEATURES DESCRIPTION

Each of the programmable features described below can be set independently for door 1 and door 2

Automatic Relock Function

When the DOOR input is used then the Automatic Relock function can be used. This feature turns the ELC relay off 1 second after the door is opened (not unlocked) when a momentary code or the RTE input has been used (no matter how long the time for the ELC relay operation has been set for in memory 83). The purpose of this feature is to stop people following someone through the door by ensuring that the door locks once it closes.

Door Open Too Long

The DOTL timer is used to warn if the door has been held open for too long after a valid access (either via a code or RTE). When the door has been opened a count down timer is started (the time set in memory 85, refer to page 13). If the door has not closed again by the time this counter expires then the DOTL output will activate (contacts will close) and will remain active until the door is closed. **Note** that if a value of 0 has been set for the DOTL time then the door is allowed to remain open indefinitely.

Door Forced Open

A door forced open condition is defined by the situation where the door has been opened but a code or RTE has not been used to gain access. When this condition occurs the DOTL output will activate (contacts will close) and will remain active for 30 seconds or until the door is closed again (whichever is the *longer* time). **Note** that the Door Forced Open feature must be disabled (set in memory 86, refer to page 14) if a free (unmonitored) inside door handle is used instead of an RTE button. When this feature is

disabled the Door Open Too Long timer will be started when the MD-02 detects the door has been opened.

One Minute Lockout

To increase security the MD-02 can be set to lock out all codes for a period of 1 minute after 5 incorrect codes have been tried (set in memory 87, refer to page 14). **Note** that this feature should not be enabled if access must be guaranteed in an emergency situation.

Use Two Codes

The MD-02 can be set up to operate in one of the four modes described below.

One User Code Only

Any one of the programmed user codes will operate the ELC relay.

Any Two User Codes

Any two of the programmed user codes can be used together to operate the ELC relay.

Code 000 or 001 and any other user code

The user code stored in memory 000 or 001 used together with any other valid user code will operate the ELC relay.

Sequentially Numbered User Codes

Two user codes in sequential memory locations must be used together to operate the ELC relay. The pair of locations start with an even numbered memory, e.g. 000 and 001, 056 and 057, 138 and 139, etc. **not** 001 and 002.

IMPORTANT NOTE: When the MD-02 is set up to use any of the two code combinations above the ELC relay will only operate in **Timed Mode** even if the codes are programmed as Toggle codes.

INSTALLATION

Read all instructions carefully before installing, programming and using the system. It is vital that all power be disconnected during wiring.

To maximize security ensure that the decoder and encoder components are separated and that the decoder is inaccessible to persons outside the restricted area. The decoder should be installed indoors and in a dry secure place. The maximum distance of separation between the decoder and encoder is 1 kilometer.

The wiring diagrams for installation are on the following pages.

BASIC KEYPAD WIRING

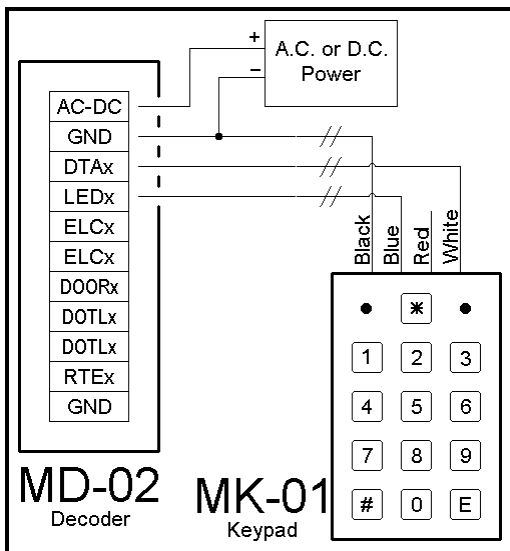

D.C. LOCK

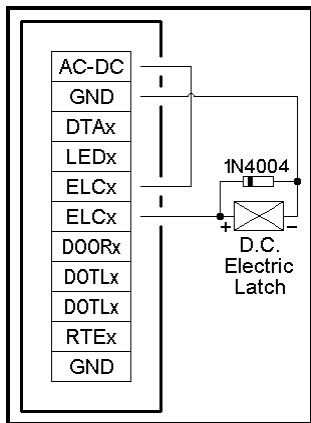

A.C. LOCK

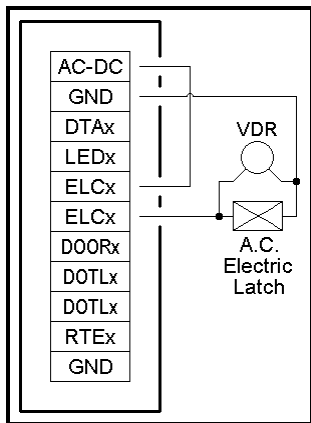

RTE SWITCH

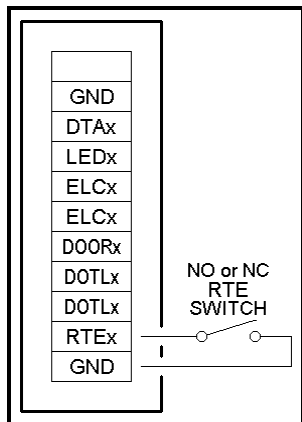

DOOR SWITCH

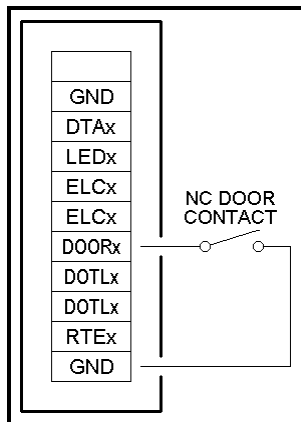

PROGRAMMING

A keypad connected to DTA1 or a MDL revision 4.0 or higher connected to DLOG is required to program the MD-02. To enable programming with a keypad the MD-02 must first be put into program mode. This is accomplished by pressing the program button located in the bottom center of the MD-02 below the "PUSH TO PROGRAM" text. When the program mode is entered the LED above the program button in the MD-02 will light up. Pressing the program button again will take the MD-02 out of program mode.

The MD-02 will remain in program mode for a period of 5 minutes after the button has been pressed. Each time the keypad is used to enter information this time is extended to 5 minutes from that time.

The MD-02 can be forced to exit program mode from the keypad by simply entering [#][9][9][E].

When the MD-02 is in program mode the green LED on the keypad will flash at a rate of once per second (provided the MD-02 has been wired as shown in the BASIC KEYPAD WIRING diagram on page 7).

IMPORTANT NOTES:

1. The **d** shown in the programming sequences must be replaced by a [1] for door 1 or [2] for door 2.
2. When programming a new Management or User code the two steps **must** be done from devices connected to DTA1. i.e. you cannot open a user location using a keypad connected to DTA1 and then enter the new user code on a keypad (or other Magic device) attached to DTA2.

KEYPAD RESPONSES

- warble = successful programming operation finished.
- 3 x 2 beeps = code memory location opened.
- long beep = unsuccessful operation.
- 1 short beep = valid Momentary or Toggle user code entered to operate ELC relay (unlock door).
- 2 short beeps = valid Toggle user code entered to deactivate ELC relay (lock door).
- 5 short beeps = valid Management code entered.

The expected response from the keypad is shown in the square brackets [] after each programming sequence.

NOTE all keys in a sequence (up to and including the [E]) must be pressed within 10 seconds of each other. If incorrect keys are pressed wait 10 seconds and then enter the sequence again.

CLEAR ALL USER CODES.

All the user codes memories (000 to 399) can be cleared by the use of the following sequence.

press [#], [8], [7], [6], [5] & [E]. [warble]

RESET ALL MEMORIES CODE.

The MD-02 can be reset to factory defaults by the use of the following sequence.

WARNING: Using this code will delete all user codes, the management code and reset memories 80 to 89 back to their default settings.

To reset the MD-02 to factory defaults...

press [#], [8], [7], [6], [5], [4], [3], [2], [1], & [E]. [warble]

BASIC SETUP SEQUENCE

- 1/ Select ELC RELAY TYPE (Currently N/O). [Memory 82, page 12]
- 2/ Select RTE switch type (Currently N/O). [Memory 81, page 12]
- 3/ Set ELC OPERATE TIME (Currently 10 seconds). [Memory 83, page 13]
- 4/ Enable/Disable DOOR INPUT (Currently disabled). [Memory 84, page 13]
- 5/ Set **D**oor **O**pen **T**oo **L**ong time (Currently 60 seconds). [Memory 85, page 13]
- 6/ Enable/Disable DOOR FORCED OPEN DETECTION (Currently enabled). [Memory 86, page 14]
- 7/ Enable/Disable AUTOMATIC RELOCK (Currently enabled). [Memory 80, page 12]
- 8/ Enable/Disable 1 MINUTE LOCKOUT (Currently disabled). [Memory 87, page 14]
- 9/ Enable/Disable USE TWO MOMENTARY CODES (Currently disabled). [Memory 88, page 14]
- 10/ Set TWO CODES TIMING, if enabled in step 9 above (Currently 60 seconds). [Memory 89, page 15]
- 11/ Program MANAGEMENT CODE. [Memory 9, page 16]
- 12/ Program USER CODES. [Memories 000 to 399, page 17]

Automatic Relock. Memory 80

(Factory Default: Automatic Relock is enabled)

Disabling the Automatic Relock function prevents the ELC relay output from deactivating 1 second after the door is opened. This function is only valid when the DOOR input is being used.

To disable the Automatic Relock function...

press *, 8, 0, **d**, 0, & E. **[warble]**

To enable the Automatic Relock function...

press *, 8, 0, **d**, 1, & E. **[warble]**

RTE Switch Type. Memory 81

(Factory Default: Normally Open RTE device)

Either a normally open or normally closed RTE switch setting may be selected.

To set the RTE switch input to normally closed...

press *, 8, 1, **d**, 1, & E. **[warble]**

To set the RTE switch input to normally open...

press *, 8, 1, **d**, 0, & E. **[warble]**

ELC Relay Type. Memory 82.

(Factory Default: ELC is Normally Open)

The electronic latch control (ELC) relay can be set to operate as either Normally Open (NO) for fail secure or Normally Closed (NC) for fail safe.

To set the ELC relay type to normally closed...

press *, 8, 2, **d**, 1, & E. **[warble]**

To set the ELC relay type to normally open...

press *, 8, 2, **d**, 0, & E. **[warble]**

ELC Operating Time. Memory 83.

(Factory Default: ELC operate time of 10 seconds)

The electronic latch control (ELC) relay can be set to operate for 1 second to 255 seconds in 1 second increments.

To change the ELC operate time...

press , , , **d**, “the time required in seconds”, & . [warble]

Door Input Enable. Memory 84.

(Factory Default: Input is disabled)

If the “Door Open Too Long” and “Door Forced Open” functions are required then the input from the door switch must be enabled. Note: enable only if your door has a magnetic contact or the latch is monitored.

To enable the door input...

press , , , **d**, , & . [warble]

To disable the door input...

press , , , **d**, , & . [warble]

Door Open Too Long Timer. Memory 85.

(Factory Default: DOTL time of 60 seconds)

The time allowed for the door to be open before a DOTL alarm is generated can be set from 1 to 9999 seconds. A time of zero seconds will disable this function.

To change the DOTL time...

press , , , **d**, “the time required in seconds”, & . [warble]

Note that time of 0 seconds will disable the DOTL function.

Door Forced Open Detection. Memory 86.

(Factory Default: DOTL is enabled)

Disabling the Door Forced Open function prevents the DOTL output from activating (contacts closing) when the door is opened without a valid code or RTE switch having been used.

To disable Door Forced Open Detection...

press [*], [8], [6], d, [0], & [E]. [warble]

To enable Door Forced Open Detection...

press [*], [8], [6], d, [1], & [E]. [warble]

One Minute Lockout. Memory 87.

(Factory Default: 1 minute lockout is disabled)

Enabling the 1 minute lockout function means that the system will not accept any codes for 1 minute after 5 successive invalid codes have been entered.

To enable the one minute lockout...

press [*], [8], [7], d, [1], & [E]. [warble]

To disable the one minute lockout...

press [*], [8], [7], d, [0], & [E]. [warble]

Use Two Codes. Memory 88.

(Factory Default: One User Code Only)

The use two codes memory is used to select the mode that the MD-02 operates in. The value programmed into memory 88 selects either One User Code Only, Any Two User Codes, Code 000 or 001 and any other user code or Sequentially Numbered User Codes. For a description of each of these operating modes refer to the **Use Two Codes** section on page 6.

To select One User Code Only mode...

press [*], [8], [8], d, [0], & [E]. [warble]

To select Any Two User Codes mode...

press [*], [8], [8], d, [1], & [E]. [warble]

To select Code 000 or 001 and any other user code mode...

press [*], [8], [8], d, [2], & [E]. [warble]

To select Sequentially Numbered User Codes mode...

press [*], [8], [8], d, [3], & [E]. [warble]

IMPORTANT NOTE: When the MD-02 is set up to use any of the two code combinations above (not One User Code Only) the ELC relay will only operate in **Timed Mode** even if the codes are programmed as Toggle codes.

Two Codes Timing. Memory 89.

(Factory Default: 60 seconds allowed between entering two codes)

If the MD-02 is set up to operate in any of the two codes modes above then the two codes must be entered within the time specified in memory 88. This time may be set between 1 and 255 seconds.

To set the time allowed between two codes...

press [*], [8], [9], d, “the time allowed in seconds”, & [E]. [warble]

The Management Code. Memory 9.

(Factory Default: No Management Code Programmed)

A management code will allow the programming of user codes without having to press the program button on the MD-02. This feature makes for greater convenience when changing codes frequently or if the decoder is difficult to reach. To add, change or delete the management code the MD-02 must be put into program mode using the program button.

The Management code can only be used to change user codes. The management code cannot be used to set programmable options or change the management code. The system will only allow for one management code. If a new management code is entered the old one will be overwritten.

The Management code must be entered before each programming operation to be performed. At the end of each successful or unsuccessful programming attempt the MD-02 will automatically revert to the Operate mode.

To add or overwrite the management code...

press [*], [9] & [E]. [3 x 2 beeps]

press “the desired management code”, & [E].
[warble]

To delete the management code...

press [#], [9] & [E]. [warble]

To enter the management mode...

press “the management code”, & [E]. [5 beeps]

User Codes. Memories 000 to 399.

(Factory Default: No User Codes Programmed)

User codes are the codes used to operate the ELC relay. These codes can be programmed as either momentary (timed) codes or toggle (bistable) codes.

When a momentary user code is used the ELC relay operates (the door opens) for the time programmed in memory 83, refer to page 13.

When a toggle code is used the ELC relay will operate and remain operating (door remains open) until a toggle code is again entered.

Remember that if the MD-02 is set up to operate using any of the two code methods then all user codes become momentary even if programmed as toggle.

Notes:

- 1/** User codes to be entered from a keypad can be 3 to 7 digits in length.
- 2/** User codes from other encoder devices can be from 3 to 9 digits in length.
- 3/** User codes can include but not start with the or digits.
- 4/** User codes cannot be overwritten. They must first be deleted and then reprogrammed.
- 5/** The same code cannot be programmed into more than one memory location.
- 6/** User codes programmed into the lower numbered memory locations will be found faster.
- 7/** Leading zeros (0) must be entered when opening a memory location.

TO PROGRAM IN A NEW USER CODE

Programming of a user code is done in two steps, first the memory location must be opened, then the user code must be entered.

When opening a memory location the type of user code to be entered for each door is also specified. This is one of Momentary, Toggle or code disabled.

Open a memory location...

press , “the memory number”, “the door 1 code type” , “the door 2 code type” & . [3 x 2 beeps]

Where “the memory number” is a three digit location from 000 to 399 and “the door code type” is either for code disabled for this door, for momentary or for toggle.

Next enter the user code...

press “the user code”, & . [warble]

TO CHANGE THE CODE TYPE

To change an already programmed code to operate in a different mode, i.e. code is programmed as Momentary for door 1 and disabled for door 2, but you now require it to be momentary for both doors, you simply reopen the memory location with the new code type for each door.

This procedure is useful if you want to temporarily disable a user code, simply set the new code type to (code disabled) for each door. This saves having to delete the code then reprogram it later.

Change the code type...

press , “the memory number”, “the new door 1 code type” , “the new door 2 code type” & . [warble]

Notice how the keypad responds with a **warble** instead of the **3 x 2 beeps** when the code type is being changed.

TO DELETE A USER CODE

Delete a user code...

press [#], “the memory number” & [E]. [warble]

Note that you do not enter the code types, nor do you need to know the actual code when deleting a user code.

Examples:

In the following examples memory location 053 has been used. All steps apply to any memory from 000 to 399.

To add a user code of 1234 as a momentary code for doors 1 & 2...

press [*], [0], [5], [3], [1], [1] & [E] [3 x 2 beeps]

Door 2 Mode
Door 1 Mode
Memory No.

press [1], [2], [3], [4] & [E] [warble]

User Code

To change the code (1234) stored in memory location 053 to a Toggle code for door 1 and Momentary for door 2...

press [*], [0], [5], [3], [2], [1] & [E]. [warble]

To disable the code (1234) stored in memory location 053 for door 1 and Momentary for door 2...

press [*], [0], [5], [3], [0], [1] & [E]. [warble]

To delete the code (1234) stored in memory location 053...

press [#], [0], [5], [3] & [E]. [warble]

REMEMBER when programming a new Management or User code, the two steps **must** be done from devices on the same DTA line. i.e. you cannot open a user location using a keypad connected to DTA1 and then enter the new user code on a keypad (or other Magic device) attached to DTA2.

Design Philosophy - Problems and Solutions.

- 1/ Most keypads contain the switching relay and control wiring within the keypad housing. A skilled person could easily bypass the keypad function simply by removing it then manipulating the control wiring, a disastrous situation. "Magic" is a 2 part system, so that the decoder can do all the processing at a remote protected environment. The code is transmitted between keypad and decoder in "computer" language, therefore cutting or shorting wires won't compromise security.
- 2/ Other keypad installations can require 7 or more wires thus increasing labor and cost. "Magic" uses only 3 wires to operate the door release, LED/buzzer feedback of code entry, acknowledgment of correct code, state of door strike, remote management code programming and power. Up to 10 keypads can be connected to a Magic decoder by simple parallel wiring. No synchronizing is required.

WARRANTY

The manufacturer will replace or repair this product if proven to be faulty (excluding accidental or malicious damage) under the 36 month warranty offered from the date of purchase.

As CROW ELECTRONIC ENGINEERING INC. or it's agents do not perform the final installation, inspection or training in the use of this product, they cannot be held liable for injury, loss, or damage directly or consequentially arising from the use or misuse of this product.

The software design of the CROW "MAGIC" is protected internationally.

Design improvement and specification changes are subject to change without notice. All designs are copyright protected.

SECURITY & PROTECTION

The following common sense hints will help to maximize the security of your system.

- don't use obvious codes such as 1234, or 888
- change codes on a regular basis
- ensure that knowledge of management and toggle codes is appropriately restricted

The Magic system has a high immunity to all types of static, EMF, and RF transmissions including those of police and CB radio systems. Reverse polarity and over voltage protection from lightning strike up to 10kV is provided.

OTHER MODELS AND ACCESSORIES

MK-01	Magic keypad encoder for Magic decoder.
MK-02	Magic Stainless Steel vandal and weather resistant keypad encoder for Magic decoder.
MIM	Magic Interface Module to convert between Wiegand, Clock/Data, Dallas iButton™ and Magic format data.
MD-01	Single Door Access Controller.
MD-06	Six open collector (logic) output decoder. 125 user codes. 12 Volt D.C. operation only.
MAGIC PROX	Magic proximity card reader for MD-01 or MD-02 controller.
MAGIC	MK-01 & MD-01 packaged together.
MAGIC 6	MK-01 & MD-06 packaged together.

PROGRAMMING SUMMARY

Note: The **d** shown in the programming sequences must be replaced by a **1** for door 1 or **2** for door 2.

Enable/Disable Automatic Relock.

*****, **8**, **0**, **d**, **x**, **E**. $x = 0$ for disabled, $x = 1$ for enabled.

Select RTE switch type.

*****, **8**, **1**, **d**, **x**, **E**. $x = 0$ for N.O., $x = 1$ for N.C.

Select ELC relay type.

*****, **8**, **2**, **d**, **x**, **E**. $x = 0$ for N.O. (fail secure), $x = 1$ for N.C. (fail safe).

Set ELC operating time.

*****, **8**, **3**, **d**, **xxx**, **E**. $xxx = 1$ to 255 (seconds).

Enable/Disable DOOR input.

*****, **8**, **4**, **d**, **x**, **E**. $x = 0$ for disabled, $x = 1$ for enabled.

Set DOTL timer.

*****, **8**, **5**, **d**, **xxxx**, **E**. $xxxx = 0$ to 9999 (seconds).

Enable/Disable Door Forced Open detection.

*****, **8**, **6**, **d**, **x**, **E**. $x = 0$ for disabled, $x = 1$ for enabled.

Enable/Disable 1 minute lockout.

*****, **8**, **7**, **d**, **x**, **E**. $x = 0$ for disabled, $x = 1$ for enabled.

Select Use Two Codes mode.

*****, **8**, **8**, **d**, **x**, **E**. $x = 0$ for One User Code Only, $x = 1$ for Any Two User Codes, $x = 2$ for Code 000 or 001 and any other code, $x = 3$ for Sequentially Numbered User Codes.

Set Two Codes timing.

*****, **8**, **9**, **d**, **xxx**, **E**. $xxx = 1$ to 255 (seconds).

Program or change the Management Code.

, , "code", .

New Management Code

Delete the Management Code.

, , .

Program a User Code.

, nnn, m1, m2, "code", .

New User Code

Door 2 Mode

- = Disabled
- = Momentary
- = Toggle

Door 1 Mode

- = Disabled
- = Momentary
- = Toggle

Memory No. 000 to 399

Change an existing User Code's operating mode.

, nnn, m1, m2, .

Door 2 Mode

- = Disabled
- = Momentary
- = Toggle

Door 1 Mode

- = Disabled
- = Momentary
- = Toggle

Memory No. 000 to 399

Delete a User Code.

, nnn, .

Memory No. 000 to 399

Exit Program Mode.

, , , .



Sole Supplier

CROW ELECTRONIC ENGINEERING INC.

2160 NORTH-CENTRAL ROAD

FORT LEE, N.J. 07024 USA

Ph: (201) 944-0005

Fax: (201) 944-1199

Toll free: 1-800 GET CROW (438-2769)