



Magic

Prox-R1

"Series 1"

**Mullion Style
Proximity Reader**

Installation Manual

1st Edition

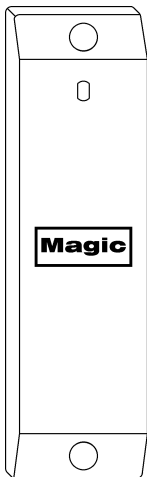

SECURITY & PROTECTION

To maximize security, your CROW Magic system splits the decoder and keypad components so that the decoder can be placed in a remote and protected environment, preventing manipulation of the control wiring and intrusion. Further, the code is transmitted in "computer" language, and therefore cutting or shorting of wires is not sufficient to compromise security.

The CROW Magic system has a high immunity to all types of static, EMF, and RF transmissions including those of police and CB radio systems. Reverse polarity protection is provided.

WARRANTY

The manufacturer will replace or repair this product if proven to be faulty (excluding accidental or malicious damage) under the 36 month warranty offered from the date of purchase.

As CROW ELECTRONIC ENGINEERING INC. or its agents do not perform the final installation, inspection or training in the use of this product, they cannot be held liable for injury, loss, or damage directly or consequentially arising from the use or misuse of this product.

The software design of the CROW Magic is protected internationally.

Design improvement and specification changes are subject to change without notice. All designs are copyright protected.

Sole Supplier:

CROW ELECTRONIC ENGINEERING INC.

2160 NORTH-CENTRAL ROAD

FORT LEE, N.J. 07024 USA

Phone: (201) 944-0005

Fax: (201) 944-1199

Toll free: 1-800 GET CROW (438-2769)

OVERVIEW

The Magic Prox-R1 Proximity Reader by Crow is an advanced, self contained RFID (Radio Frequency IDentification) contactless reader. It is capable of interfacing to either a Wiegand input control panel or to Crow's new range of Series 4 Magic decoders.

The mullion styling makes the Prox-R1 suitable for door frame mounting as well as other mounting positions.

OPERATION

Connected to a Magic Series 4 decoder

The LED on the reader is red when ready to read a Magic prox card. When a card is presented to the front of the reader the LED momentarily turns orange to indicate that the Prox-R1 has read it. The code is then transmitted to the Series 4 decoder.

If the card is valid the Prox-R1 will respond with 1 or 2 short beeps and the LED will change to green (provided the blue wire is connected as shown in the wiring diagram) for the time the ELC relay is active (door is released).

If the card is invalid the Prox-R1 will respond with a "blarp" (long beep).

Connected to a Wiegand controller

The LED on the reader is red when ready to read a Magic prox card. When a card is presented to the front of the reader the LED momentarily turns orange and the internal buzzer gives a short beep to indicate that the Prox-R1 has read it. The code is then transmitted to the Wiegand controller.

The LED can be made to change color to green by the controller by applying +5 to 16 Volts D.C. to the blue wire.

SPECIFICATIONS

- Voltage:- 8 to 16 Volts D.C.
linear power supply recommended.
- Current:- 140mA max @ 16 Volts D.C.
- Size:- 150mm x 44mm x 20mm.
- Outputs:- 26 bit Wiegand, Pulse Width = 50 μ s,
Pulse Separation = 2ms.
and Magic Series 4 decoder format.
- Read Range:- Up to 7" (18cm).
- Wiring Distance:- 0.6 mile (1Km) from Prox-R1 to Series 4
Magic Decoder (100 Ω max. return resistance,
unshielded cable).
100 ft (30m) from Prox-R1 to Wiegand
controller, using shielded 24AWG cable.
- Excitation Frequency:- 125 KHz.
- Operating Temperature:- 32°F to 158°F (0°C to 70°C).
- 36 month (3 year) manufacturer's warranty.
- Designed and manufactured in Australia.

MOUNTING

Use the supplied mounting template to mark the cable entry and two mounting holes. **Note** that the cable entry to the Prox-R1 is near the bottom screw hole.

WIRE COLORS

- Red - +8 to 16 Volts D.C.
- Black - Ground.
- Green - Wiegand Data 0.
- Yellow - Wiegand Data 1.
- Blue - LED Control.
- White - Series 4 Magic DTA line (connect to Ground when using Wiegand).
- Drain - Shield/Ground (connect to Ground at controller).

DIMENSION DIAGRAMS

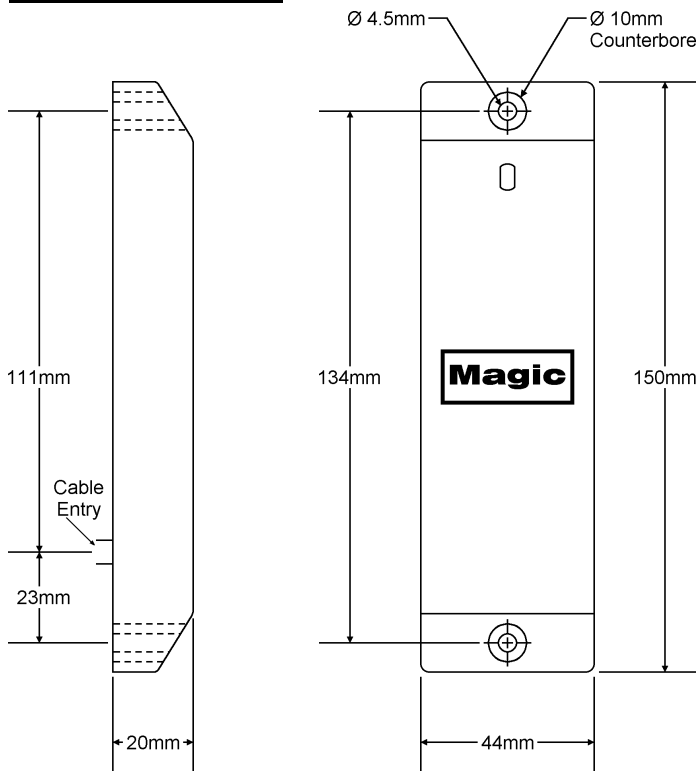

WIRING DIAGRAMS

Connecting the Prox-R1 to a Series 4 Magic decoder

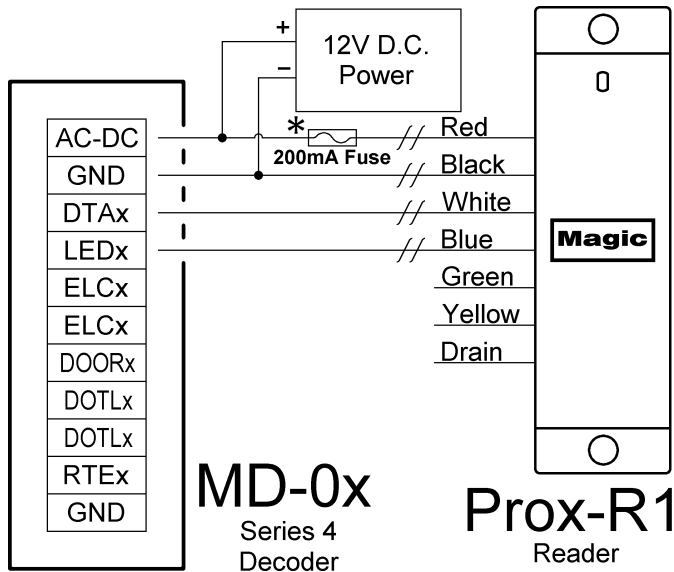

Note that the Green, Yellow and Drain wires on the Prox-R1 are not connected when it is used with a Series 4 decoder.

* Use a 200mA inline fuse to protect the power supply from short circuiting if Prox-R1 wires are tampered with. This is particularly important when using fail safe (power to lock) locking mechanisms.

Connecting the Prox-R1 to a Wiegand controller

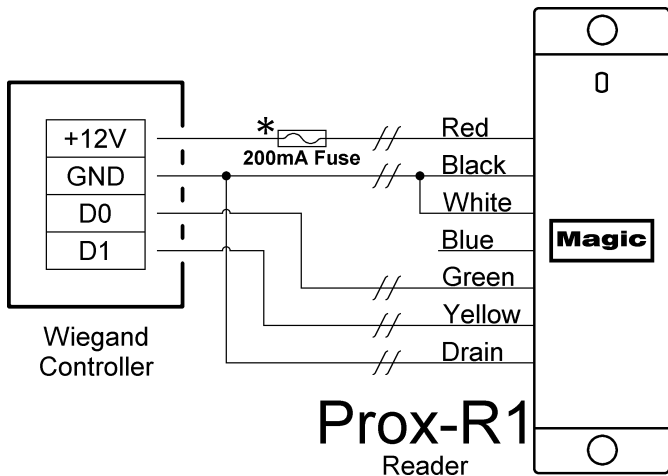

Note that the White wire is connected to GND (Black wire) at the Prox-R1, but the Drain is connected to GND at the Wiegand controller.

The Blue wire controls the LED on the Prox-R1. When a high voltage (+5 to +16V D.C.) is applied to this wire the LED will change to Green. This is normally connected to the switched positive side of the Electronic door release mechanism.

* If the controller does not provide a fused output for readers use a 200mA in-line fuse to protect the power supply from short circuiting if Prox-R1 wires are tampered with.

